

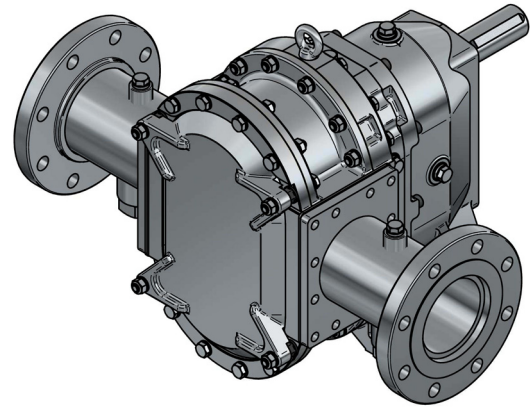

M50



SPECIFICATIONS	US	Metric
Rated Capacity:	0-300 gpm	0-68 m ³ /h
Displacement (per 100 revolutions):	50 gal (US)	189 L
Maximum Continuous Pressure:	125 psi	8.6 bar
Starting Torque:	1,273 in lbf	144 N m
Rated Speed:	0-600 RPM	0-600 RPM
Shaft Diameter:	1.65"	42 mm
Flange Connection Class:	ANSI 16.5-150#	DN – PN 16
Flange Connection Size:	ANSI 4"	DN 100
Weight:	290 lbs	132 kg
Solids Handling:		
Spherical Compressible	1.5"	38 mm
Spherical Hard*	1/8"	3 mm

* Larger hard solids will pass through but may cause damage.

Positive Displacement Rotary Lobe Pumps

MODEL >	SM50	CM50	DM50
Service	Sludge, Mud and Slurries*	Chemical/Corrosive	Oil, Gas & Abrasives
WETTED PARTS			
Rotary Lobes			
Elastomer	NBR Opt. HNBR, FKM, EPDM or Eng. Rec.	FKM or HNBR Opt. NBR, EPDM or Eng. Rec.	FKM or HNBR Opt. NBR, EPDM or Eng. Rec.
Lobe Profile	Helix	Helix	Helix
Number of lobe wings	4	4	4
Core	Carbon Steel	Carbon Steel	Carbon Steel
Sealing Elastomers			
O-rings	FKM	FKM or Engineer Recommendation	FKM or Engineer Recommendation
Lip seals	FKM or Engineer Recommendation	FKM or Engineer Recommendation	FKM or Engineer Recommendation
Mechanical Seals			
Mechanical Seal	Duronit Opt. Tungsten Carbide, Silicon Carbide, or Eng. Rec. Carbon Steel with Corrosion resistant coating	Silicon Carbide Opt. Tungsten Carbide or Engineer Rec. Stainless Steel Type 316	Tungsten Carbide Opt. Silicon Carbide or Engineer Rec. Duplex Stainless Steel
Seal Holders			
Wear Plates	AR500 Steel (Brinell 500)	Duplex Stainless Steel	Duplex Stainless Steel
Housing Segments	ASTM A48 Grey Iron rust primed	Duplex Stainless Steel	Duplex Stainless Steel
Flange Ring	ASTM A36 Carbon Steel	Stainless Steel Type 316L	Duplex Stainless Steel
Bolts	Carbon Steel ISO 898-I	Stainless Steel A2-A4	Duplex Stainless Steel
Pressure Disc	Stainless Steel Type 316L	Stainless Steel Type 316L	Duplex Stainless Steel
LIMITED EXPOSURE PARTS			
Quench /Seal Cooling Chamber	ASTM A48 Grey Iron rust primed	ASTM A48 Grey Iron with PTFE / Ceramic Teflon etched on face	ASTM A48 Grey Iron with PTFE / Ceramic Teflon etched on face
Pump Cover	ASTM A48 Grey Iron rust primed	CIT coated Grey Iron Opt. 316 Stainless Steel	CIT coated Grey Iron Opt. Duplex Stainless Steel
NON-WETTED PARTS			
Gears	GMA Class 9 AISI 1045 steel	GMA Class 9 AISI 1045 steel	GMA Class 9 AISI 1045 steel
Gear Housing	ASTM A48 Grey Iron rust primed	ASTM A48 Grey Iron rust primed	ASTM A48 Grey Iron rust primed
Shaft	AISI 4140 Alloy Steel	AISI 4140 Alloy Steel	AISI 4140 Alloy Steel
PAINTING REQUIREMENTS			
Standard Painting	SSPC/SP6 Sandblast Paint LobePro Blue	SSPC/SP6 Sandblast Paint LobePro Silver	SSPC/SP6 Sandblast Paint LobePro Silver

NOTE: Listed above are standard pump assemblies; lobe styles and materials subject to recommendation by LobePro Engineering. A wide range of optional materials are available for each model. Consult LobePro for further information. *Consult Factory for application temperature above 80°C (175°F).

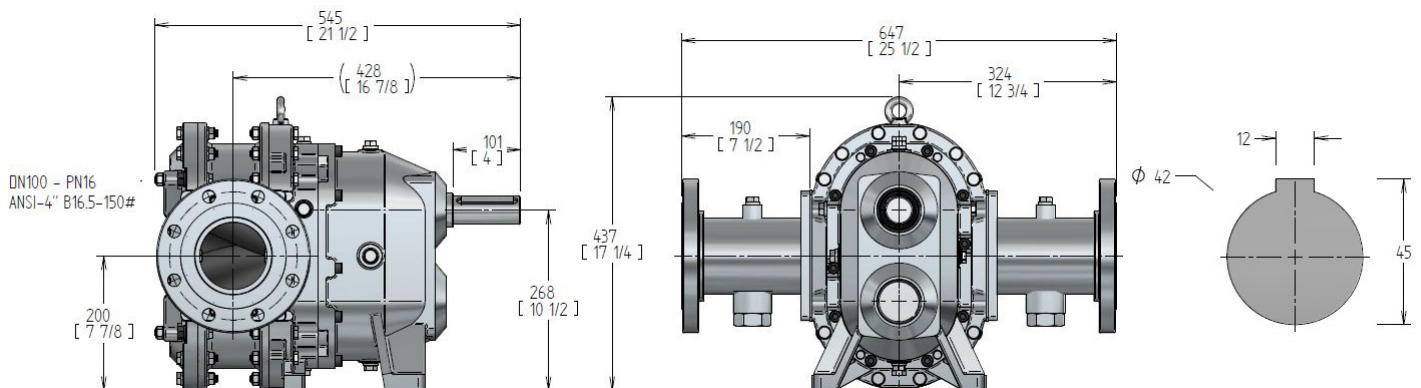

Section 40-15

4 September 2020

M50 CURVES

Performance Curve - NBR Lobes*

Based on 70°F (21°C) fresh water (1 cp) at Sea Level.
Output will increase as viscosity of the fluid increases from 1.

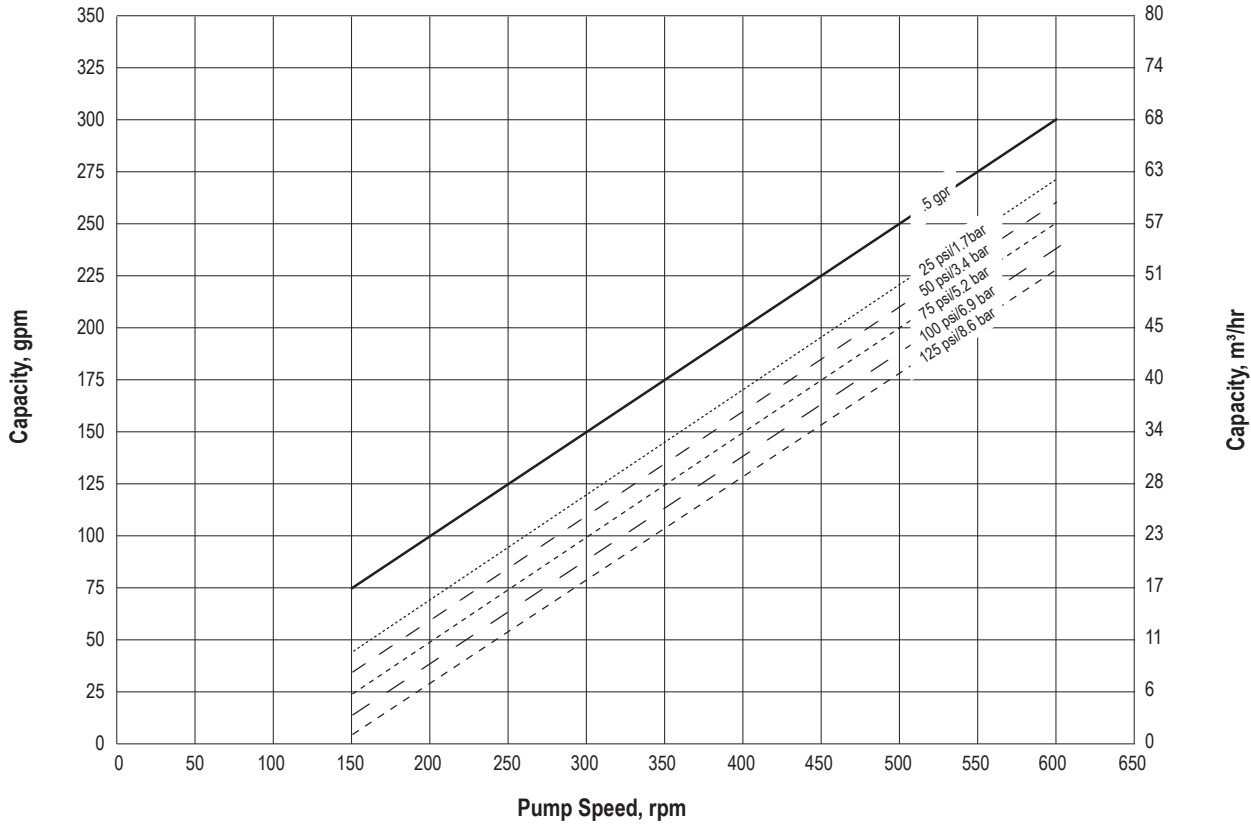

*Note: Output from lobes coated with elastomers other than NBR maybe lower. Contact Engineering for further information.

Horsepower Requirements

